

VELZENER

Maschinen GmbH



ESTROMAT 426-5

Operators manual



Art.-Nr.: 426.00.009

Stand: 01.2016

CONTENTS

ESTROMAT 426-5

Mixing, pump and spray unit for refractories

	Page
INDEX.....	1
1. OPERATING INSTRUCTIONS.....	3
1.1 Preface	3
1.2 Description.....	4
1.3 Function	5
1.4 Technical Data.....	6
1.5 Installation and operation instructions.....	7
1.5.1 Installation of unit	7
1.5.2 Connection of unit	8
1.5.3 Electric control.....	8
1.5.4 Check of rotor direction	9
1.5.5 Control of pump pressure.....	9
1.5.6 Preparation of mortar line.....	9
1.5.7 Starting the continuous mixer	10
1.5.8 Starting the mortar pump.....	10
1.5.9 Mortar spraying	10
1.5.10 Short work breaks	11
1.5.11 Cleaning mixer and mortar pump	11
1.5.12 Cleaning of mortar hose(s).....	12
1.5.13 Maintenance of the unit.....	12
1.5.14 General safety regulations	13
1.6. Faults and their mending	15
2. LUBRICATION PLAN	17
2.1 Gear motors.....	17
2.2 Continuous mixer.....	17
2.3 Mortar pump	17

- 3. MAINTENANCE INSTRUCTIONS 18**
 - 3.1 Continuous mixer 18
 - 3.1.1 Cleaning the wet zone of mixer 18
 - 3.1.2 Cleaning the dosing zone..... 18
 - 3.2 Mortar pump 19
 - 3.3 Water armature..... 19
 - 3.4 Air armature 20
 - 3.5 Vibrators 20
- 4. Wiring diagram..... 21**

1. OPERATING INSTRUCTIONS

1.1 Preface

Before you start your ESTROMAT 426-5 unit, please read this operator's manual very carefully. The operator of this machine should know very well who to handle the machine to avoid mistakes and damages.

Conscientious maintenance and correct operating will give your machine a long life and good service.

Please note that guarantee expires, if your machine is not operated and maintained appropriately. In case of questions, please do not hesitate to contact us or our branches and agents at home and abroad. We will be pleased to give you any information you may desire.

The manufacturer or his agents do not assume any liability for spare-, wear and other parts which have not been delivered by the manufacturer or his agents. No guarantee will be given for damages arising as a result of using non-original spare parts.

Claims against the manufacturer cannot be asserted out of his operator's manual, in particular not those which concern construction of building up the machine.

These operator's manual and the spare parts list are subject to modifications in the interest of a permanent improvement of the machine.

Please note that the present operator's manual is valid for different executions of this type of machine. Changes of the described technical equipment of this machine are not possible.

When you order spare parts, please let us know the order-numbers shown in the spare parts list, the type of machine and machine-number.

We wish you success with your new ESTROMAT 426-5

UELZENER MASCHINEN GMBH
Stahlstrasse 26-28
D-65428 Rüsselsheim
Phone: +49 6142-177 68 0
Fax: +49 6142-177 68 50
e-mail: contact@uelzener-ums.de

1.2 DESCRIPTION OF UNIT ESTROMAT 426-5

The ESTROMAT 426-5 is a complete unit for lining tundishes in steel mills.

It consists of:

Part 1: A steel frame with ladder, platform and rails detachable for transport herein included:

Part 2: Dry mortar silo with BIG-BAG-cutter detachable for transport

Part 3: BIG-BAG-cutter

Part 4: Fluidifying system on dry mortar silo with compressed air control (Option)

Part 5: ... Vibrator for dry mortar silo

Part 6: Continuous mixer

Part 7: Water dosage control

Part 8: Vertical mortar pump

Part 9: Gearbox motor for mortar pump (as option with variable speed)

Part 10: .. Level probe for wet mortar hopper

Part 11: .. Vibrator for mortar pump

Part 12: .. Electric control panel

Part 13: .. Air control box for

a: Fluidifying system (Option)

b: Remote control for spraying nozzle device

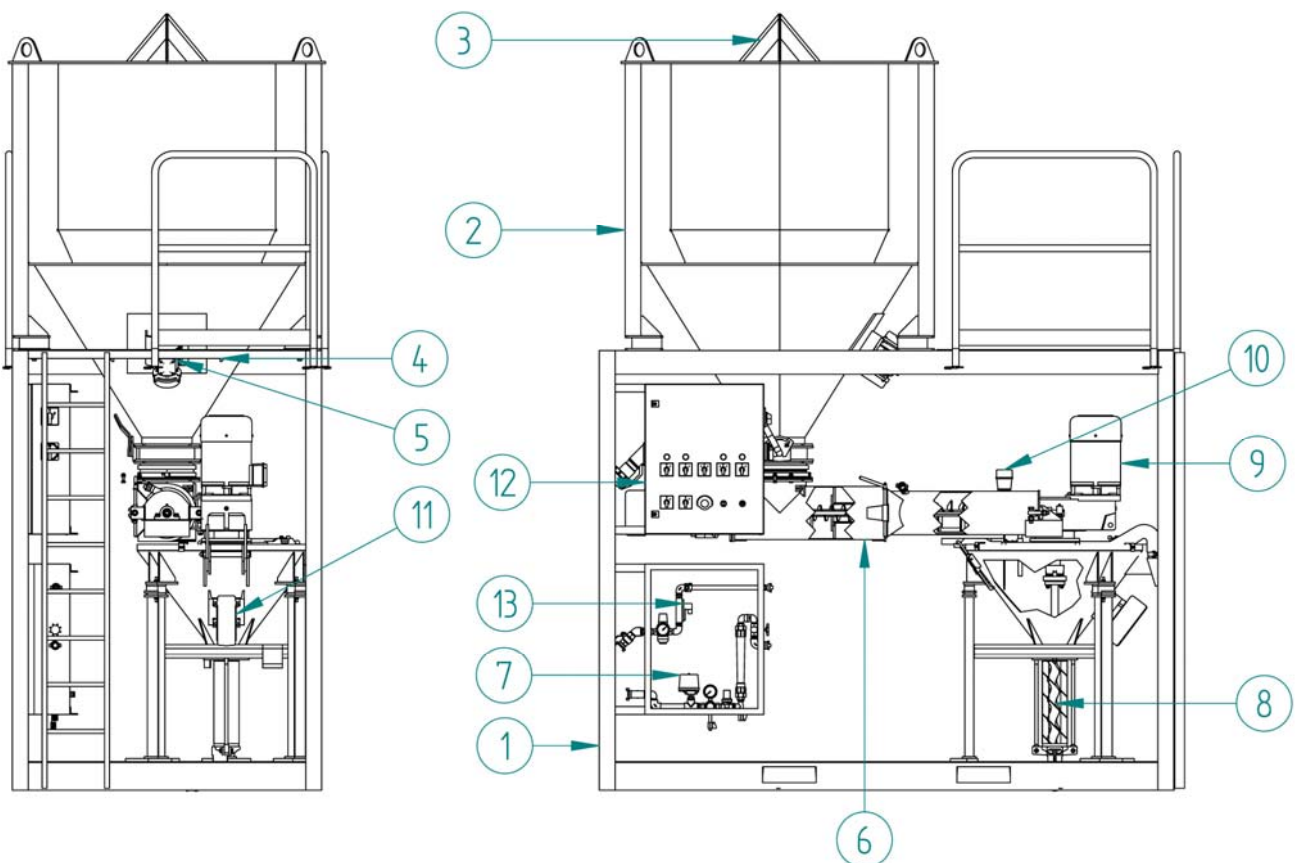

1.3 FUNCTION

The dry mortar which is fed by BIG-BAG'S into the dry mortar silo (Part 2) flows into the continuous mixer (Part 6)

From the continuous mixer the dry mortar is transported by the dosing shaft into the mixing chamber where the required water quantity is added. The mixing shaft now mixes the dry mortar with water and the mixed mortar falls into the wet mortar hopper of the vertical pump (Part 8).

The level probe inside the wet mortar hopper (Part 10) controls the mortar level and switch the continuous mixer automatically on and off according the requirements of the pumps.

The mixed mortar is delivered by a screw pump through the pump outlet into the conveying hose(s) assisted by the vibrator build on the wet mortar hopper (Part 11). The level probe stops and restart the continuous mixer, if the mortar level inside the wet mortar hopper is low after 15 seconds (adjustable), so that a continuous working is possible by avoiding dry running of the screw pump.

The mortar will convey to the spray gun. The spray gun has a second connection for compressed air. This compressed air makes it possible to spray the mortar onto the tundishes. By opening and closing the valve for compressed air on the spray gun the conveying starts and stops the mortar to the spray gun (Automatic-mode)

The electric control panel (Part 12) includes all necessary devices for automatic running. Therefore, only one person is needed to operate the ESTROMAT 426-5 unit.

1.4 TECHNICAL DATA IN GENERAL

Volume of dry mortar silo:	approx. 2m ³
Compressed air connection:	R 1", System GEKA
Fluidifying system (Option)	200 -500 l/min, 0,5 bar
Required compressed air:	300 – 600 l/min, 3 bar
Mixing capacity**	approx. 50 l/min
Water connection:	R 1", System GEKA
Required water pressure:	min. 3 bar
Conveying capacity**:	approx. 40 l/min***
Screw pump (Rotor / Stator)	UE 355, soft
Pump outlet:	ID 50, System SK 50
Vibrator on dry mortar silo:	0,3 kW, max. 6 kN
Vibrator on wet mortar hopper:	0,18 kW, max. 2,6 kN
Total length:	3150 mm
Total width:	1780 mm
Total height:	3900 mm
Transport height:	2290 mm (without silo)
Weight loaded:	4800 kgs
Weight unloaded:	1800 kgs

**Depending on quality of material, hose diameter and length of hose(s)

*** with standard pump-gearbox-motor,

by using the adjustable speed gearbox-motor up to 70 l/min (Option)

This unit is in accordance with VDE0100 as well as with the safety regulations of the Construction Society

Operating voltage	400V / 50Hz	415V / 50Hz	440V / 60 Hz	220V / 60Hz
Power connection:	532/6h 3P,N,E or 563/6h (water heating system)			563/9h 3P,N,E
Power input	Approx. 14kW (Option + 6kW for water heating system)			
Control voltage	24V=			
Connection cable	4mm ² (10mm ² with water heating system)		16mm ³	
Fuses	32A (63A with water heating system)		63A	
Type of enclosure	IP54			
Motor continuous mixer	5,5 kW			
Motor mortar pump	7,5 kW			

1.5 INSTALLATION AND OPERATING INSTRUCTIONS

1.5.1 INSTALLATION OF UNIT

The ESTROMAT 426-5 is completely assembled and wired before leaving the factory.

The following work has still to be carried out after installing the unit:

- Add plug-in railing for the platform and secure it by using feather keys
- Install dry mortar silo with tear-open device
- Install vibrator at the dry mortar silo
- Connect electric supply
- Connect water supply
- Connect compressed air supply

There is no need to fasten the unit to the ground, but it should be levelled. The unit can be transported by lifting it on the 4 jack rings on top of the base frame or by fork lifting it by means of openings provided at the longer sides of base frame.

MOUNTING

- I Plug the 3 single railing parts into the pipe sockets
- II Lift dry mortar silo on 4 jack rings into specified position on silencer block and fasten it by using hexagon nuts (one for each block)
- III Connect continuous mixer to flange of butterfly valve at the dry mortar silo
- IV Connect to water supply. The connector is a quick-fit coupling, Type GEKA
Water supply requirements: 4 bar minimum, diameter R3/4"
Flow pressure: 3 bar, approx. 1500 l/h
Operating pressure: 2,5 bar
- V Connect to compressed air supply, 3 bar minimum, diameter R 1"
The pneumatic connector to the dry mortar silo for fluidization is a quick-fit coupling, Type GEKA
Pressured air supply requirements: 4bar minimum, diameter R1" 500-800 l/min
Fluidization pressure: 0,5 – 0,8 bar
Spraying pressure: 2-2,5 bar
- VI Connect to electric supply via fault-current breaker. The system is basically 5-wire (3-phases, neutral and protection wire), fitted with a plug.

1.5.2 CONNECTION OF UNIT

Turn off the main switch and all other switches. Connect main cable at electric control box. Observe right operating voltage. The current distributor has to be equipped with a fault-current breaker.

Connect water hose min. ID= 3/4" with GEKA-Coupling

Connect air hose min ID=3/4" with GEKA-Coupling

Adjust air pressure of fluidifying system at 0,5 bar

Adjust air pressure of spraying system at 2,5 bar

1.5.3 ELECTRIC CONTROL

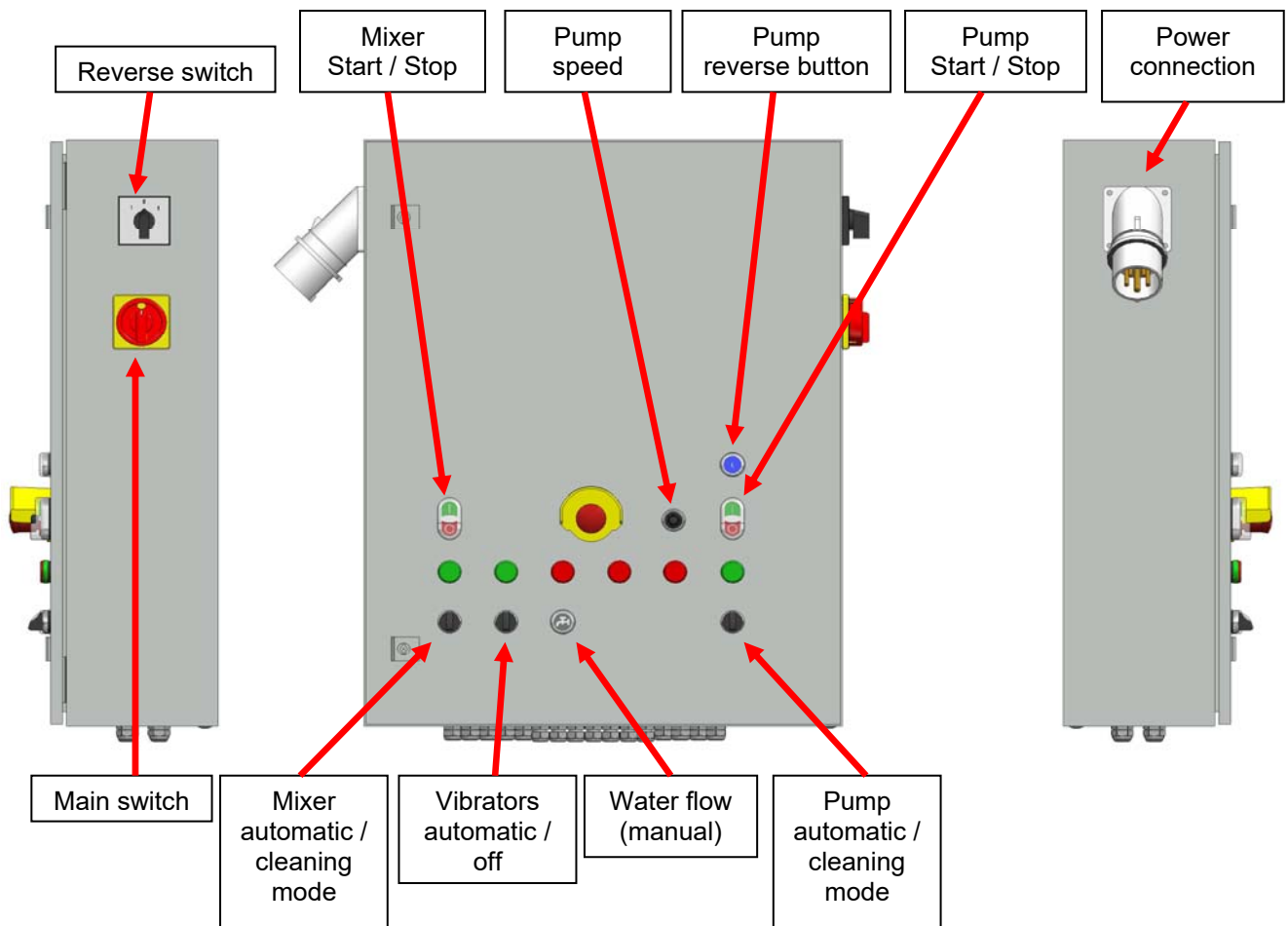

INDICATOR LIGHTS

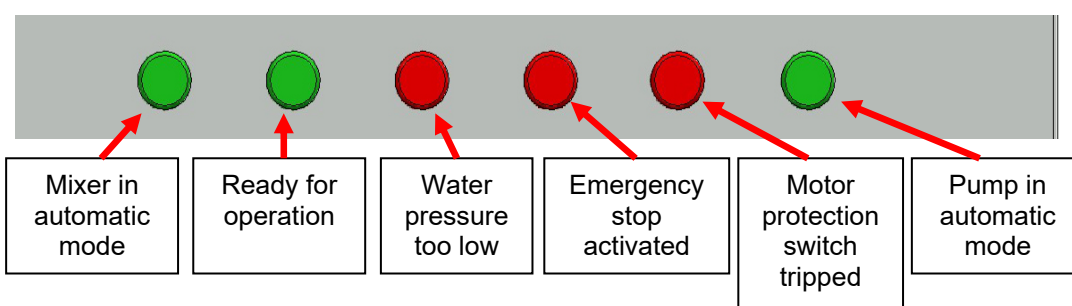

1.5.4 CHECK OF ROTOR DIRECTION

All motors are polarized in the same direction: this means that only rotor direction of mixer has to be checked.

- Switch on the main switch
- Switch on the reverse switch to position 1
- Switch the mixer in “CLEANING MODE”
- Switch on the mixer and check the direction

If the direction is wrong, switch the reverse switch to position 2

1.5.5 CONTROL OF SCREW PUMP PRESSURE

Install the screw pump (rotor/stator) on the wet mortar hopper. Connect the mixing shaft, close and lock the motor panel. Fill approx. 5 l water inside the wet mortar hopper. Connect the mortar pressure manometer on the pump outlet. Connect the control device on the mortar pressure manometer and close the ball valve on the control device. Start the pump motor in the “CLEANING MODE” and check the pressure on the mortar pressure manometer. The pressure should show 15 – 20 bar at the maximum. If pressure of pump decreases or increases considerably, tighten or loosen the screws of the pump jacket. Repeat pressure test. If having adjusted right pressure, open ball valve on the control device and disconnect the control device.

1.5.6 PREPARATION OF MORTAR LINE

Only use high pressure ORIGINAL-UENZENER mortar hoses with original bound couplings.

We recommend the following hose diameters for different conveying lengths:

ID 25 for conveying length up to 20 m

ID 35 (Standard) for conveying length up to 30m

ID 50 at the beginning of conveying line and length over 30m

The hoses have to be in accordance to the regulations of the Construction Society.

Before connecting the hose(s), the mortar pressure manometer has to be connected to the pump outlet. Always take care that all hose couplings and sealing's are clean. Dirty or untied coupling seals cause a leakage of water and as a result stoppers.

Before the hoses can be used, they must be watered inside. Add approx 2-3 liters of water in the first tube. By lifting the hose, the water flows out again. (Required)

Always lay mortar hose(s) the shortest way, but not buckling the hose(s).

The air hose (ID ½") has to be laid parallel to the mortar hose. Both, mortar and air hose have to be connected to the spray gun.

1.5.7 STARTING CONTINUOUS MIXER

Switch the mixer in "AUTOMATIC MODE"

Open butterfly valve of dry mortar silo before starting! By using a pneumatic flap the flap opens automatically in "AUTOMATIC MODE"

Disconnect water hose from the mixing tube. Push the "water flow" switch shortly and adjust water dosage valve on flow meter at approx. 750 l/h.

Switch the vibrators in "AUTOMATIC MODE".

Switch continuous mixer for a short while (5 seconds), so that dry material runs into the mixing tube. Reconnect water hose to the mixing tube. Start continuous mixer in automatic-mode, check mortar consistency, regulate water quantity, if necessary.

Wet mortar has a soft consistency and should not segregate.

Observe regulations of the material manufacturer!

After required level in wet mortar hopper is reached, the mixer is automatically switched off by wet probe inside the wet mortar hopper.

1.5.8 STARTING THE MORTAR PUMP

After filling the hopper with wet mortar, the pump can be started as follows:

- Close the air valve on spray gun
- Open the air valve on air control box
- Switch on the pump in automatic mode
- Open the air valve on spray gun (remote control by air valve on spray gun)

1.5.9 MORTAR SPRAYING

The mortar should be sprayed with a calm and even movement of the spray gun.

You have to take care that mortar is always applied with same thickness.

If you wish a special thick coating, we recommend two subsequent spraying processes.

1.5.10 SHORT WORK BREAKS

Work can be stopped at any time without special precautions while there is material in pump hopper and hose, but please pay attention to the fact that the break has to be shorter than the setting time of mortar (see recommendations of material manufacturer). In general, segregations because blockages of the pump and by using sticky mortar, the pump may run dry due to cavitations in hopper.

1.5.11 CLEANING OF UNIT IN ITS WET ZONE

Unit and mortar line have to be cleaned after spraying operation at the end of a shift or respectively before longer breaks:

1. Mixer switch in cleaning mode
2. Close flap of silo and run continuous mixer until it is empty. By using a pneumatic flap the flap, it automatically closes in cleaning mode
3. Switch off continuous mixer, remove bearing shield and mixing shaft and clean these parts with water. Mixing tube fold down and clean with water. Make sure, that no water gets into the dosing zone of the continuous mixer. Than mount everything again.
4. Pump wet mortar hopper empty as much as possible, however, take care that screw pump does not run dry. Release pressure from mortar hose, run pump shortly in reverse mode, switch over reverse switch at control box.
5. After mortar pressure manometer indicates that there is no pressure in mortar hose anymore, disconnect mortar hose.

ATTENTION!

Even if machine does not pump, especially in cases of blockages, there is always a very high pressure in the mortar hose. Therefore, always release pressure before disconnecting the hose. In addition, wear protective goggles and turn your face away when opening the hose couplings.

6. Clean wet mortar hopper with water, let pump run shortly until clean water comes out of pump outlet

1.5.12 CLEANING OF MORTAR HOSE

Disconnect spray nozzle and air nozzle from the spray gun.

Put two sponge balls into mortar hose and connect hose to the pump outlet.

Pump water into mortar hose until sponge balls comes out of the end.

However, it is better to connect mortar hose directly to water hose to prevent wear and tear of screw pump.

Note:

Never clean mortar hose by using water only without a sponge ball because bigger particles of mortar may remain in the hose which may cause stoppers when starting work again.

Spray nozzle and air nozzle have to clean separately with water, especially function of remote control air valve and jet tube have to be checked.

1.5.13 MAINTENANCE OF UNIT

In case of frost danger empty all water fittings, drain valves at pressure reduction and water meter. If the unit stands idle for a long time, dry mortar hopper has to be emptied and cleaned by air.

Lift off mixer motor and remove all dry materials. Clean wet part of mixer carefully and dismantle pump parts from time to time to check wear and tear.

Disconnect machine from power supply before doing maintenance and lubrication work. Check if machine is without voltage.

Lubricate nipples at motor flange of mixer and pump motor, hinge clamp and bearing of mixing shaft daily until lubricant comes out. Recommended lubricants: Multipurpose lubricants 4862 DIN 51801- 51818.

Check flat seal of driving shaft of wear and tear every 100 operate hours.

Clean radiator rib of motor from dust and mortar

1.5.14 GENERAL SAFETY REGULATIONS

We would like inform you of the most important safety regulation in order to ease working and to ensure working without any risk with our ESTROMAT 426-5

OPERATING INSTRUCTIONS

1. ESTROMAT 426-5 has been constructed for mixing, conveying and spraying of mineral materials. When operating the machine, observe operating instruction of manufacturer carefully.
2. The manager has to employ only reliable staff trained in operation and maintaining the machine and who studied these operating instruction very well.
3. Install the machine in a stable manner and secure it with suitable devices to prevent unintentional motion.
4. Electrically driven machines have to be connected to a special feeding point (e.g. power distribution on building sites with fault current breaker).
5. Before starting the machine, ensure that no one will be endangered by the machine in operation.
6. Do not reach into the opening of mixer!
7. Any installations for precaution must not be changed or be removed and have to be operated according to the instructions.
8. Works at electric control are only to be carried out by an electric expert or by instructed personnel supervised by an electric expert.
9. Conveying hoses are to be laid in such a way that the vibrations can be controlled by suitable retaining points (hose hooks). This applies especially to vertical lines.
10. Conveying hoses are to be laid in such a way that they cannot be damaged. At places where the direction changes, the radius of curvature may not be less than 6 times the outer line diameter.
11. Only use original UELZENER high pressure mortar hoses with couplings installed at the factory.
12. When starting the machine, it must be ensured that the conveying hoses contains an adequate prepublication, that easily pumped mortar is used and that leaks are avoided at the connection points.
13. After actuation or failure of the machine's safety devices, its operation is to be interrupted until elimination of fault.

14. Before disconnecting any hoses or other pressure bearing parts of the conveying system, it has to be ensured that there is no pressure in the system.
15. Blockages in the mortar hoses are to be eliminated according to the instructions in the operation manual. The operator entrusted with the elimination of blockages must stand in such way that he cannot be hit by released mortar. No other person stand in the vicinity.
16. All devices for safety and accident prevention are not changed or removed and are to be operated properly.
17. Switch off main switch during all cleaning and repair works.
18. Check working safety before starting the machine. As soon as any faults are discovered, they have to be repaired immediately, if necessary, inform the supervisor or in case of faults which endanger working safety stop operation.
19. Accidents which are due to non-compliance with the accident prevention regulations or the responsible liability insurance company or the legislation of your country or lack of care and attention, will be attributed to the responsibility of the machine operator by the legislation or of the supervisory personnel if the machine operator cannot be held liable because of the lack of training or basic knowledge.

Please observe the particular safety regulations.

Surveillance and testing of machine:

1. The operator has to check the machine for apparent defects before every work shift.
2. A technical expert has to check the machine for reliable operating condition, when required, but at least once a year.

Technical experts are persons who, on the basis of their technical training and experience, have adequate knowledge in their field of mortar conveying and mortar spraying machines. They are sufficiently familiar with the relevant state labor protection regulations, accident prevention regulations, guidelines and generally recognized rules of technology and they can evaluate the safe working condition of this machine.

Personal protection equipment for the machine operator

The operator has to wear protective glasses when eliminating blockages.

1.6 FAULTS AND THEIR MENDING

FAULT	CAUSE / MENDING
- Motor does not work	<ul style="list-style-type: none"> - No current supply, check fuses, motor protection switch - Phase failure
- Mixing motor stops	<ul style="list-style-type: none"> - Not enough water pressure - Water filter dirty - Clogged mortar in water inlet of mixing chamber
- Not enough output	<ul style="list-style-type: none"> - Butterfly valve not fully open - Not enough dry mortar in silo - Silo vibrator does not work - Dosing shaft worn - Mixing shaft worn - Mixing shaft clogged
- Mortar too stiff	<ul style="list-style-type: none"> - Check water dosage
- Mortar too thin	<ul style="list-style-type: none"> - Reduce water (see also not enough output) - Dosing zone wet, clean it
- Pump motor stops	<ul style="list-style-type: none"> - Mortar too stiff, therefore pump motor is overloaded - Air valve at pneumatic remote control is closed - Air jet is blocked - Blockage in mortar hose - Adjustment of flow meter not correct
- Pump motor is working, but no mortar output	<ul style="list-style-type: none"> - Check pump, maybe stator or rotor worn - Mortar is too thick and therefore not sucked into the pump - Mortar hose is too long in relation to pump pressure - Pump outlet is blocked - Vibrator on wet mortar hopper does not work

<ul style="list-style-type: none"> - Mortar conveying stops 	<ul style="list-style-type: none"> - Check mortar pressure at first, be aware of stoppers in mortar hose! - Try to find position of stopper in hose by carefully touching hose starting at the end. - Put on your protective goggles! Let the pump motor run backwards for a short time until mortar pressure =0 bar. (Machine without frequency inverter: switch the reverse switch and start the pump motor, machine with frequency inverter: press the pump return button) - Uncouple hoses - Stopper remove by flushing with water - Cleaning the hoses with water and rubber ball
<ul style="list-style-type: none"> - Dust coming out of silo 	<ul style="list-style-type: none"> - Pressure of (optional) fluidisation is too high, max. 0,5bar
<ul style="list-style-type: none"> Vibration of unit is too strong 	<ul style="list-style-type: none"> - Adjust silo vibrator

3. LUBRICATION PLAN

2.1 LUBRICATION PLAN OF GEAR MOTORS

Gearbox motors have no lubrication nipples. Only gearbox oil is to be changed.

Type of oil: ISO VG 220

Maintenance rate: after 4000 hours or after two years

Filling rate of gear box mixer motor: 0,5l

Filling rate of gear box pump motor: 3,8l

2.2 LUBRICATION PLAN – CONTINUOUS MIXER

Lubrication point	Maintenance rate
Lubrication nipple at sealing of motor shaft	1x daily
Lubrication nipple at bearing of mixing shaft	1x daily
Lubrication nipple at hinged bolt	1x weekly

2.3 LUBRICATION PLAN – MORTAR PUMP

Lubrication point	Maintenance rate
Lubrication nipple at sealing of motor coupling	1x daily

Type of grease recommended: multipurpose grease 4682 DIN 51801 – 51818

3. MAINTENANCE INSTRUCTIONS

3.1 CONTINUOUS MIXER E 401

The Continuous Mixer ESTROMAT 401 is practically maintenance-free and requires only some cleaning work and greasing of lubrication nipples at regular intervals.

ATTENTION!

During all maintenance work at mixer, especially when using water, switch off main switch at electric control panel.

The following work must be carried out in regular intervals:

3.1.1 CLEANING WET UNIT OF MIXER E 401

- remove pillow block by opening the two snap-on holders
- remove mixing shaft and clean it with water thoroughly
- check mixing shaft for wear and tear and, if necessary, replace by original spare part
- unlock and swing down mixing chamber at quick-fit connector end
- carefully clean mixing chamber of mortar with water and brush by moving from connector end towards dosing shaft (no water in dosing zone!)
- assemble in reverse order

3.1.2 CLEANING DRY MORTAR DOSING ZONE

- close butterfly valve
- unhinge gear motor after releasing snap-on lock on motor hood
- pull out dosing shaft (transport screw shaft) and clean it from agglomerated dry mortar residues without using water
- check dosing shaft for wear and tear and replace, if necessary, by original spare part

3.2 MAINTENANCE INSTRUCTIONS - MORTAR PUMP

The mortar pump is practically maintenance-free. All it needs is to be cleaned and lubricated at regular intervals - one lubrication nipple at motor shaft seal.

A T T E N T I O N !

During all maintenance work at mortar pump, especially when using water, switch off main switch at electric control panel.

CARRY OUT THE FOLLOWING WORK IN REGULAR INTERVALS

- Clean mortar hopper with water after each spraying operation.
- Run pump for a short while with mortar hose disconnected to empty wet mortar hopper of soiled water.
- Unscrew tension screws of stator cover to remove and clean pump outlet.
- Remove pump and clean with water. Strip down pump and check rotor and stator for wear and tear. If necessary, insert original spare parts.
- Remove and clean pump suction flange. Check if O-ring is inserted properly.
- Pull out cardan shaft and remove remaining mortar pieces by using water.
- Check flat seal of motor coupling for wear and tear and replace it, if necessary, by original spare part.
- Grease motor coupling according to lubrication plan 2.3
- Assemble in reverse order
- Check pump pressure according to operating instruction 1.5.4, before each spraying operation. Also check connection of drive shaft to rotor head.

3.3 MAINTENANCE – WATER ARMATURE

Water armature of spray unit ESTROMAT only requires a minimum of maintenance. Water in all control devices has to be released, if there is danger of frost.

The dirt filter in input coupling has to be cleaned, depending on the degree of water pollution. The pressure reducer does also have a pan sieve in sieve cup. In order to open it, a special wrench is required (standard tool set).

The solenoid valve does not have a sieve. Occasionally, you have to check if relief well of valve membrane is dirty. Water flow meter is made of thermoplastic material. Water temperature must not exceed 35°C. Maintenance is not required.

3.4 MAINTENANCE - AIR ARMATURE

Air armature of spraying unit ESTROMAT 426 only needs a few maintenance care.

Air has to be dry and lubrication-free.

Pressure reducer has got a pan sieve in the sieve cup. When opening, use a special key (standard tool set) in any case.

Empty water separator of air armature weekly.

Solenoid valve does not have a sieve. Occasionally, you have to check if relief well of valve membrane is dirty.

Flow meter is fixed on an outflow of 1,5 Nm³ of compressed air at factory.

According to air armature, the set-point can/has to be changed, so that the mortar pump can be controlled by air valve at spray gun (automatic mode).

3.5 MAINTENANCE - VIBRATOR

Surface of vibrator has to be kept free of dirt in order to secure an adequate cooling.

Fitting screws have to be retightened after 2 hours.

Greasing of bearings is normally not necessary. Bearings are lubricated sufficiently for life time.

If vibrator is stripped or bearings are replaced, only clean cloth should be used.

Never run equipment without unbalance.

Permissible operating temperature: 80° C

Permissible load current has not to be exceeded.

Unbalance adjustment:

For adjusting centrifugal force, two protective hoods have to be removed. It is necessary to make same adjustment on both sides.

Adjustment by factory: pump hopper: 15%, dry mortar hopper: 60%

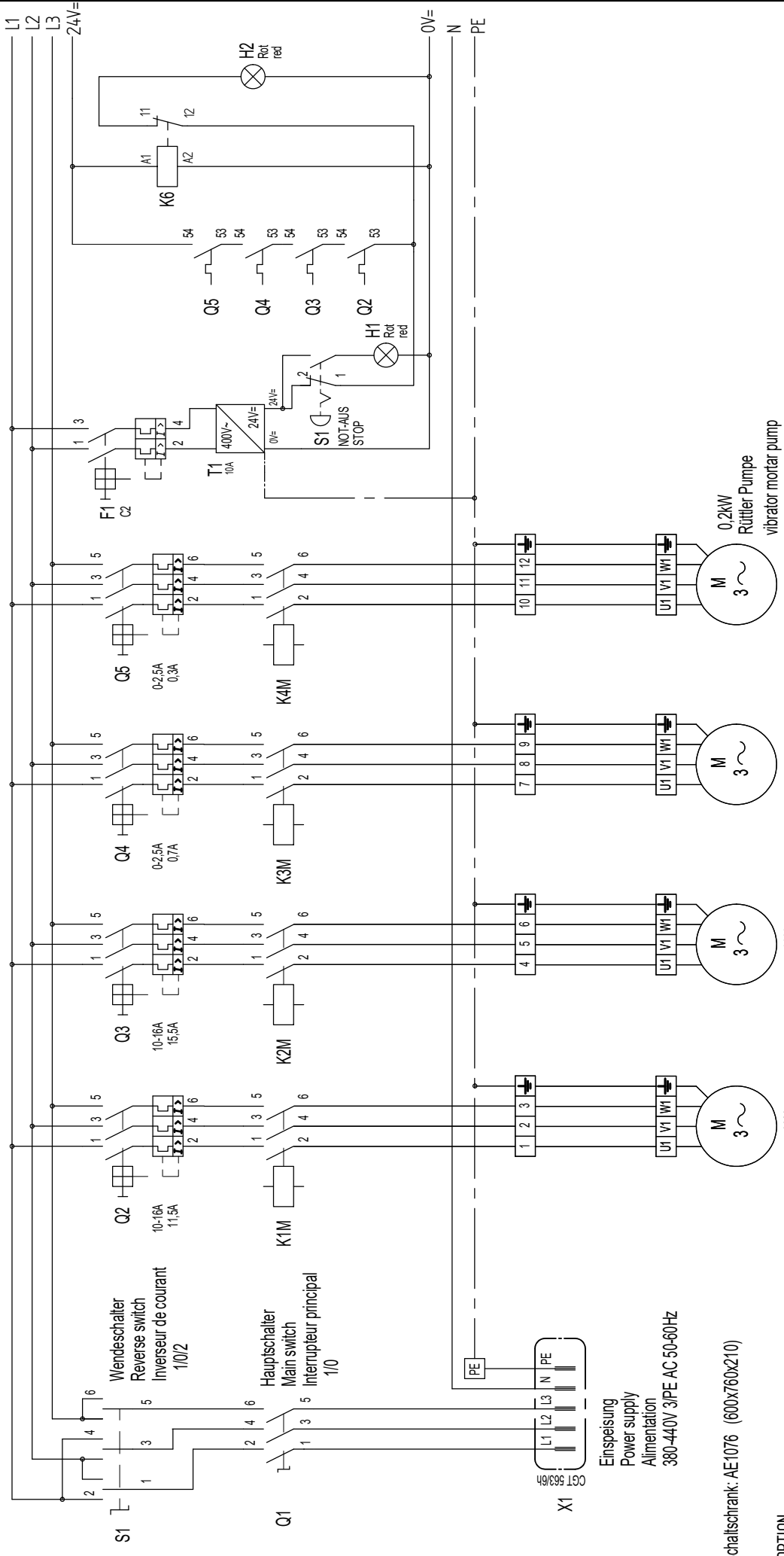

Schaltschrank: AE1076 (600x160x210)

*OPTION

Tag	Name	UeLZENER MASCHINEN GmbH
Gez.	U.F.	Stahlfraße 26-28
Gepr.	Art der Änderung	65428 Rüsselstein
Num.	Name	ESTROMAT E426-5
Rev. A		Standard-Version
Rev. B		
Rev. C		
Rev. D		
Rev. E		
Tolerierung nach DIN ISO 8015		
Allgem. Toleranzen für Schweiß- und Biegekonstruktionen: DIN 8570 T1B / T3F		
Allgem. Toleranzen für Maßtolerierung, Form und Lage : DIN ISO 2768-m		

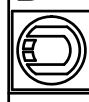

C-1801-24

CAD: D:\Zeichnungen\Software\Elektrotechnik\baureit\c-1801-24.dft
 Urspr.
 Ers. fuer.
 Ers. durch.
 Massstab 1:X

Das Urheberrecht an dieser Zeichnung verbleibt bei uns.
 Diese Zeichnung darf weder kopiert noch Dritten zugänglich gemacht oder anderweitig mit Unbefugten benutzt werden.

L1
L2
L3
24V=

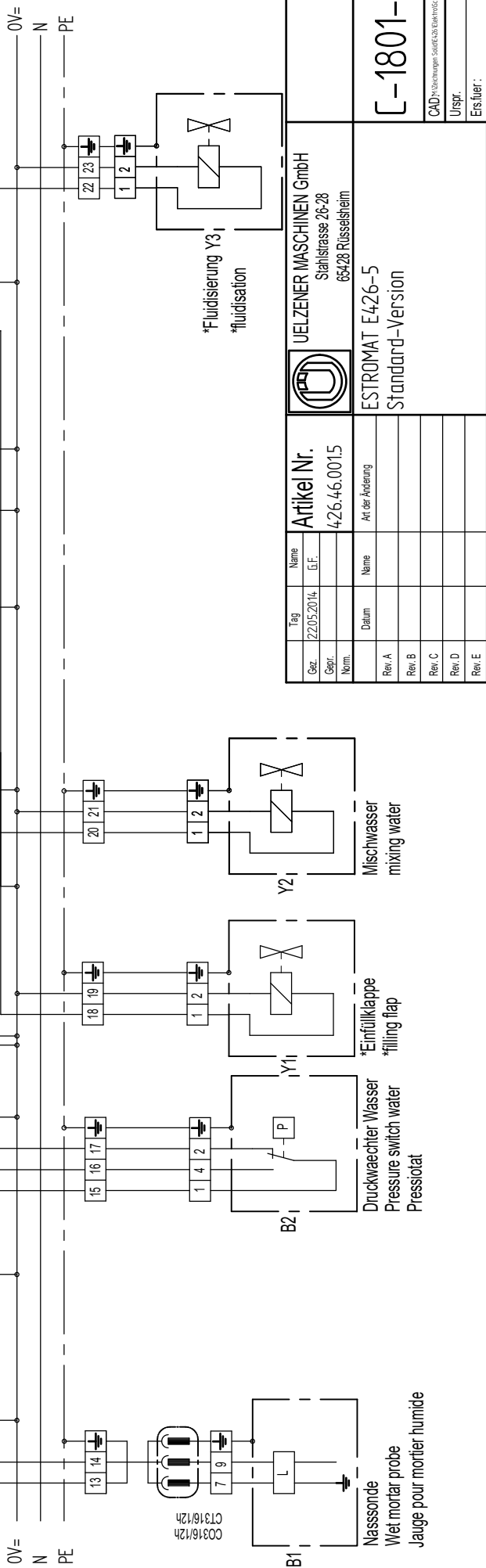
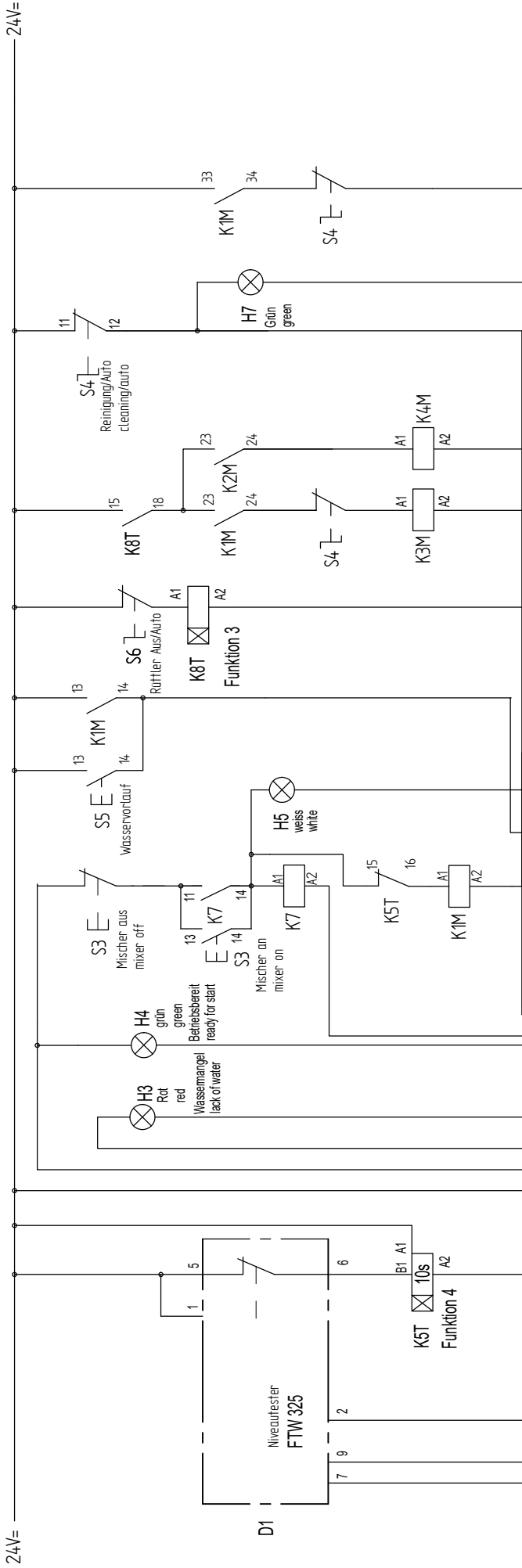

Tag	Name	UELZENER MASCHINEN GmbH
Gez.	G.F.	Stahlfraße 26-28
Gepr.		65428 Rüsselstein
Norm.	Artikel Nr.	ESTROMAT E426-5
	Art der Änderung	Standard-Version
Rev. A	Name	
Rev. B		
Rev. C		
Rev. D		
Rev. E		

C-1801-24

CAD: *D:\zeichnungen\50461256\Estromat\Estromat_C-1801-24.dft
Urspr.
Ers.fuer.:
Ers.durch.:
Massestab 1 : X

Tolerierung nach DIN ISO 8015
Allgem.Toleranzen für Schweiß- und Biegekonstruktionen: DIN 8570 T1B / T3F
Allgem.Toleranzen für Maßtolerierung, Form und Lage : DIN ISO 2768-m

Das Urheberrecht an dieser Zeichnung verbleibt bei uns.
Diese Zeichnung darf weder kopiert noch Dritten zugänglich gemacht oder anderweitig mit Unkenntnis unserer Rechte benutzt werden.

L1
L2
L3
24V=

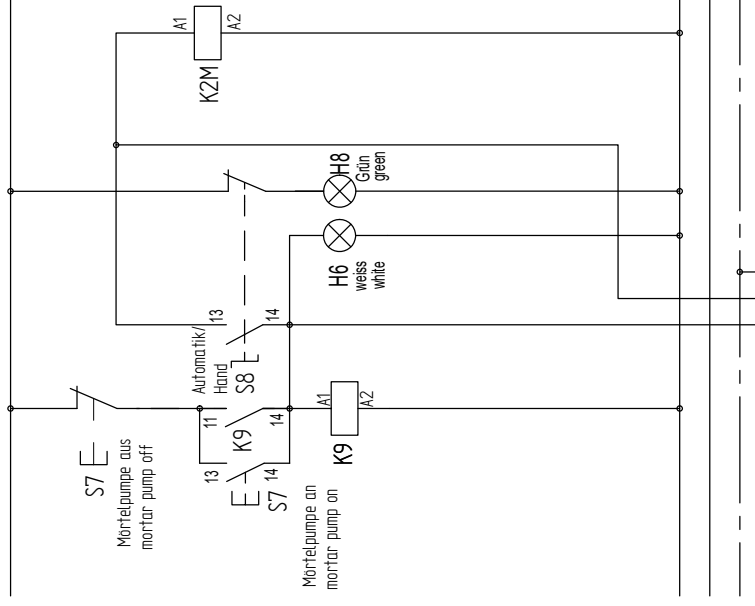

UELZENER MASCHINEN GmbH
Stahlfraße 26-28
65428 Rüsselsheim

Artikel Nr.
426.46.0015
Art der Änderung

Tag	Name
22.05.2014	G.F.
Datum	Name
Rev. A	
Rev. B	
Rev. C	
Rev. D	
Rev. E	

ESTROMAT E426-5
Standard-Version

C-1801-24

CAD: 7/Übungen/SoSe14/26/Estromat/Estromat-3012.dft
Urspr.
Ers.für:

Tolerierung nach DIN ISO 8015
Algem.Toleranzen für Schweiß- und Biegekonstruktionen: DIN 8570 T1B / T3F
Algem.Toleranzen für Maßtolerierung, Form und Lage : DIN ISO 2768-m

Das Urheberrecht an dieser Zeichnung verbleibt bei uns.
Diese Zeichnung darf weder kopiert noch Dritten zugänglich gemacht oder anderweitig mit elektronischen Mitteln benutzt werden.

Ers.durch:
Massstab 1 : X

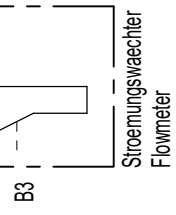

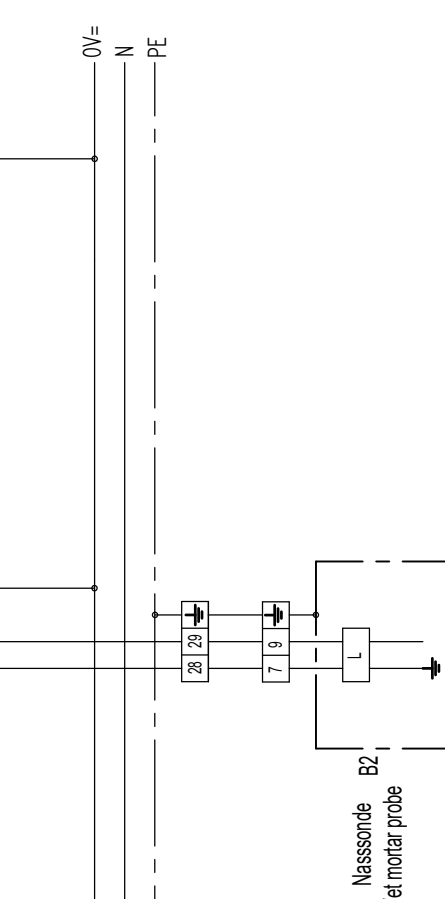
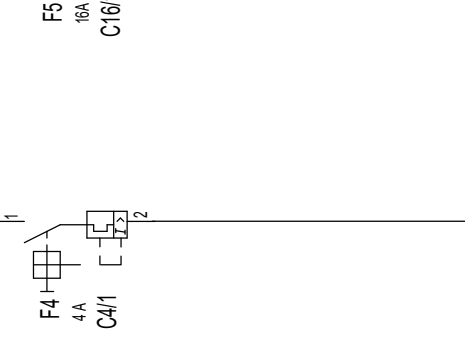
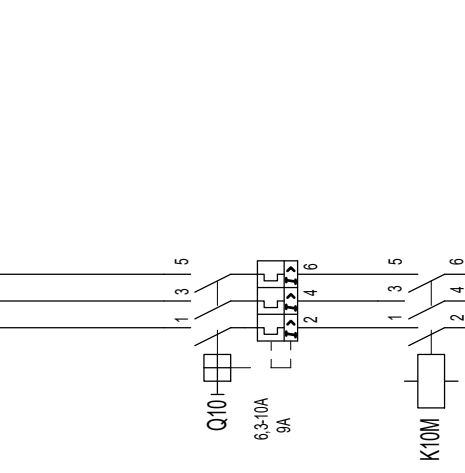
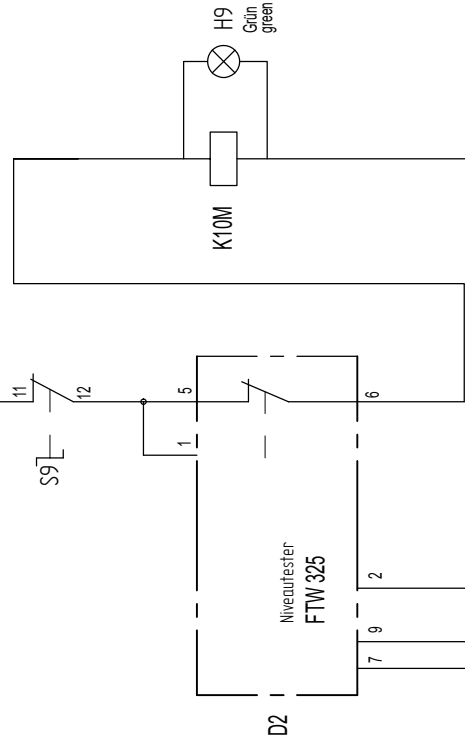
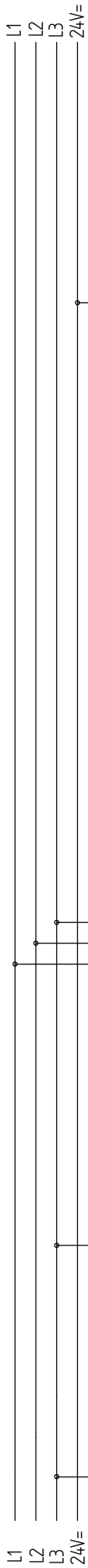

Tag	Name	UELZENER MASCHINEN GmbH
22.05.2014	G.F.	Stahlfraße 26-28
Gez.		65428 Rüsselstein
Gepr.		
Norm.	426.46.0015	
	Name	ESTROMAT E426-5
	Art der Änderung	Standard-Version
Rev. A		
Rev. B		
Rev. C		
Rev. D		
Rev. E		

Artikel Nr. 426.46.0015

Urspr. :
Ers.für. :
Ers.durch. :
Massstab 1 : X

Tolerierung nach DIN ISO 8015
Allgem.Toleranzen für Schweiß- und Biegekonstruktionen: DIN 8570 T1B / T3F
Allgem.Toleranzen für Maßtolerierung, Form und Lage : DIN ISO 2768-m

Das Urheberrecht an dieser Zeichnung verbleibt bei uns.
Diese Zeichnung darf weder kopiert noch Dritten zugänglich gemacht oder anderweitig mit Unbefugten benutzt werden.

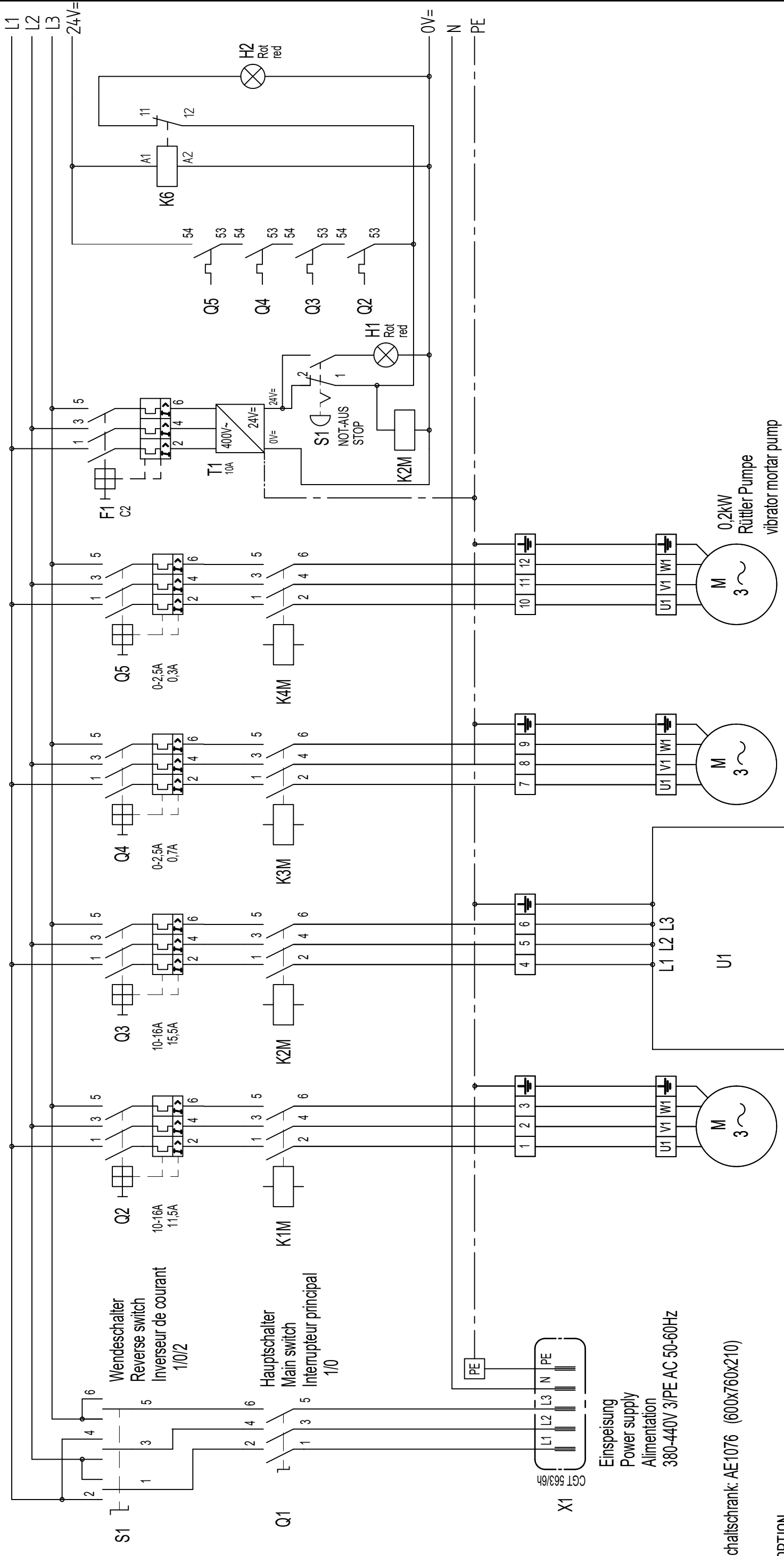

Gez.	30.11.2017	Tag	Name	UELZENER MASCHINEN GmbH Stahlstrasse 26-28 65428 Rüsselsheim	
Gepr.			G.F.	Artikel Nr.	ESTROMAT E426-5 FU-Version
Norm.				426.46.001.5	
Rev. A		Datum	Name	Art der Änderung	
Rev. B					
Rev. C					
Rev. D					
Rev. E					

Tolerierung nach DIN ISO 8015		Das Urheberrecht an dieser Zeichnung verbleibt bei uns.	
Allgem. Toleranzen für Schweiß- und Biegekonstruktionen: DIN 8570 T1B / T3F		Diese Zeichnung darf weder kopiert noch Dritten zugänglich	
Allgem. Toleranzen für Maßtolerierung, Form und Lage : DIN ISO 2768-m		gemacht oder anderweitig mäßig benützt werden.	
Ers. durch:		Ers. durch:	
Massstab		1 : X	

Schallschrank: AE1076 (600x760x210)

*OPTION

C-1801-24FU

CAD: V1 Zeichnungen: S:\e426\Elektro\Schaltplane\C-1801-24-FU.rvt
Urspr.
Ers. fuer:
Ers. durch:

L1
L2
L3
24V=

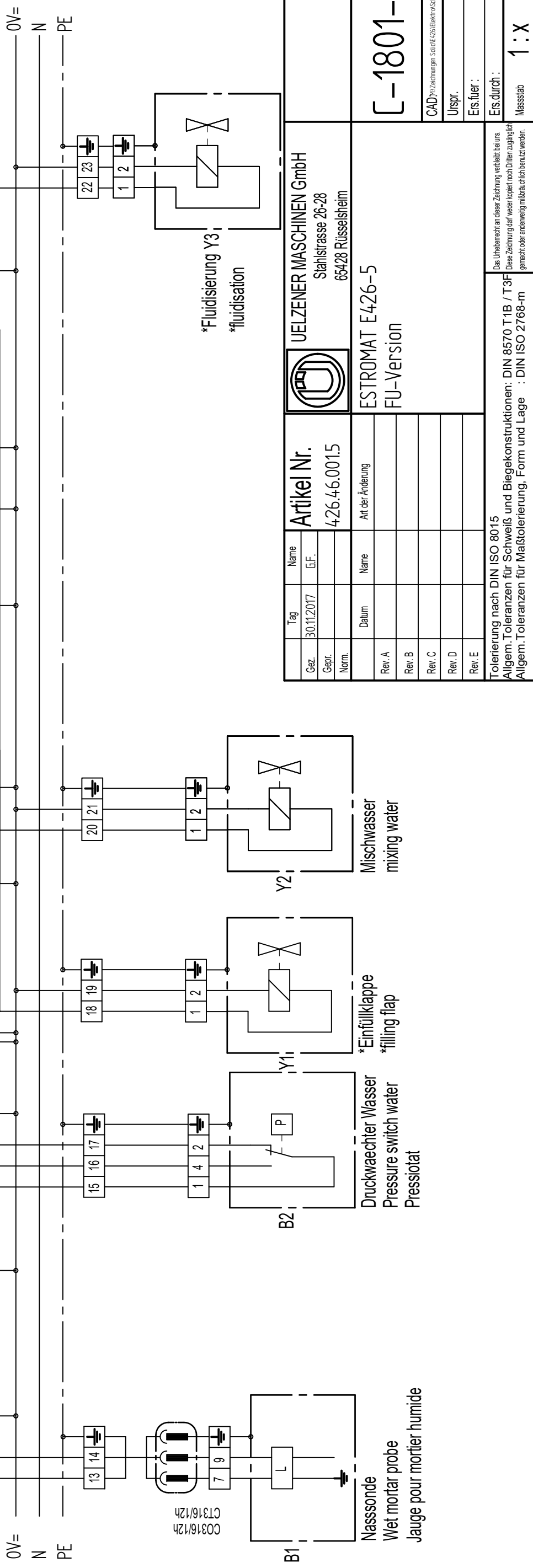
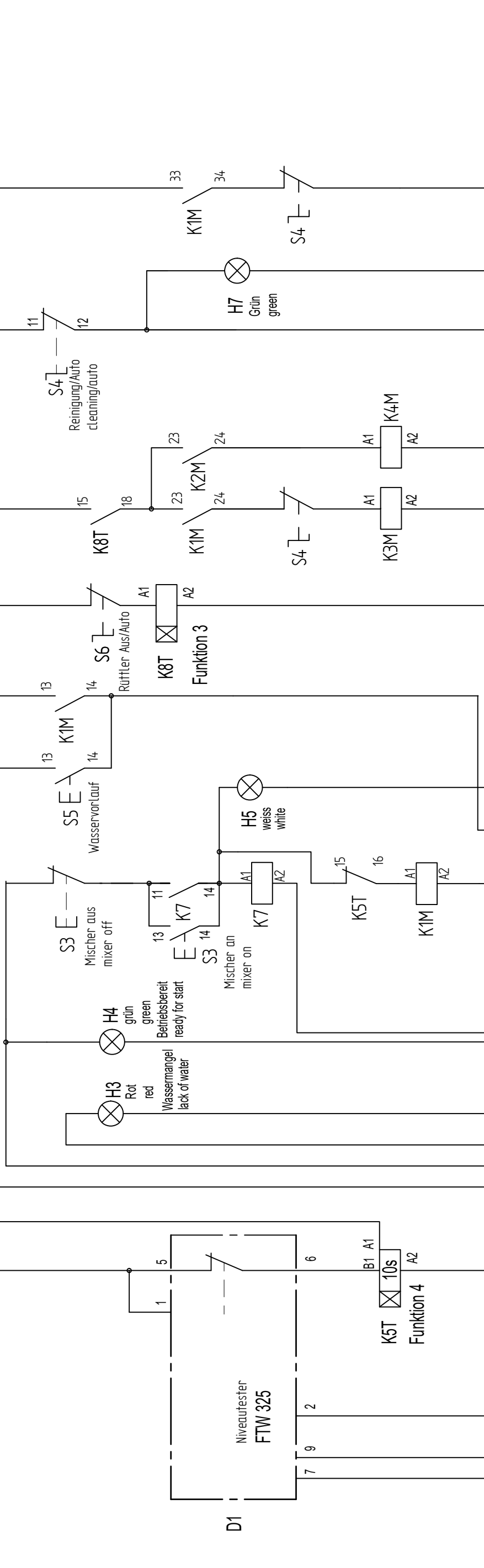

		UELZENER MASCHINEN GmbH Stahlstrasse 26-28 65428 Rüsselsheim	
Gez.	30.11.2017	Tag	Name
Gepr.			G.F.
Norm.			
Rev. A		Datum	Name
Rev. B			
Rev. C			
Rev. D			
Rev. E			
ESTROMAT E426-5 FU-Version		Artikel Nr. 426.46.0015	Art der Änderung
C-1801-24FU			
CAD: V Zeichnungen: SahlE426/ElektroSchaltplaneC-1801-24-FU.tif		Urspr.:	
EIS.fuer:		EIS.durch:	
Massstab		1 : X	

Tolerierung nach DIN ISO 8015
 Allgem. Toleranzen für Schweiß- und Biegekonstruktionen: DIN 8570 T1B / T39F
 Allgem. Toleranzen für Maßtolerierung, Form und Lage : DIN ISO 2768-m

Das Urheberrecht an dieser Zeichnung verbleibt bei uns.
 Diese Zeichnung darf weder kopiert noch Dritten zugänglich gemacht oder anderweitig mündlich benützt werden.

L1
 L2
 L3
 24V=

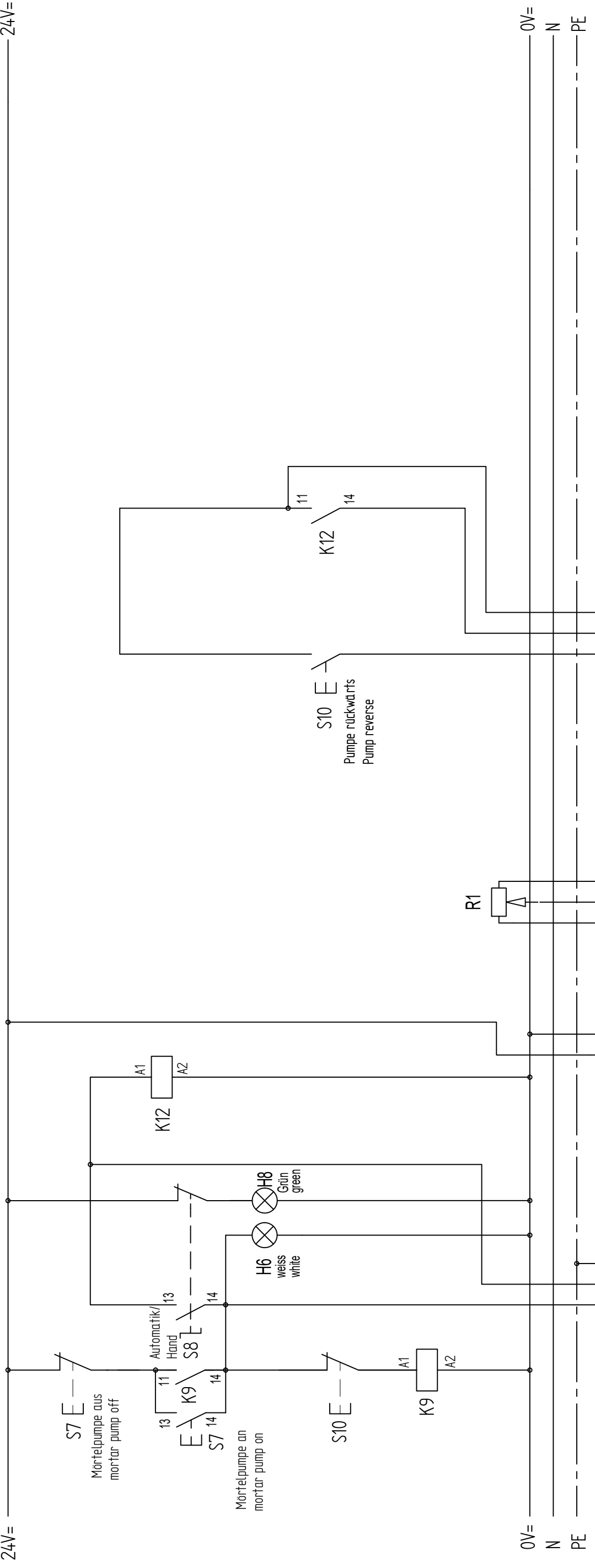

UJ		UJELZENER MASCHINEN GmbH Stahlstrasse 26-28 65428 Rüsselsheim	
Artikel Nr.		ESTROMAT E426-5 FU-Version	
Tag	Name	Tag	Name
30.11.2017	G.F.		
Gepr.		Gepr.	
Norm.		Norm.	
Rev. A		Rev. A	
Rev. B		Rev. B	
Rev. C		Rev. C	
Rev. D		Rev. D	
Rev. E		Rev. E	
Tolerierung nach DIN ISO 8015		Tolerierung nach DIN ISO 8015	
Allgem. Toleranzen für Schweiß- und Biegekonstruktionen: DIN 8570 T1B / T3F		Allgem. Toleranzen für Schweiß- und Biegekonstruktionen: DIN 8570 T1B / T3F	
Allgem. Toleranzen für Maßtolerierung, Form und Lage : DIN ISO 2768-m		Allgem. Toleranzen für Maßtolerierung, Form und Lage : DIN ISO 2768-m	
Urspr.		Urspr.	
Ers.fuer:		Ers.fuer:	
Ers.durch:		Ers.durch:	
Massstab		Massstab	
1 : X		1 : X	

CAD Zeichnungen: StahlE426/ElektroschaltplaneC-1801-24-FU.tif
 Urspr.
 Ers.fuer:
 Ers.durch:
 Massstab

C-1801-24FU

Das Urheberrecht an dieser Zeichnung verbleibt bei uns.
 Diese Zeichnung darf weder kopiert noch Dritten zugänglich gemacht oder anderweitig in ähnlicher Weise benutzt werden.

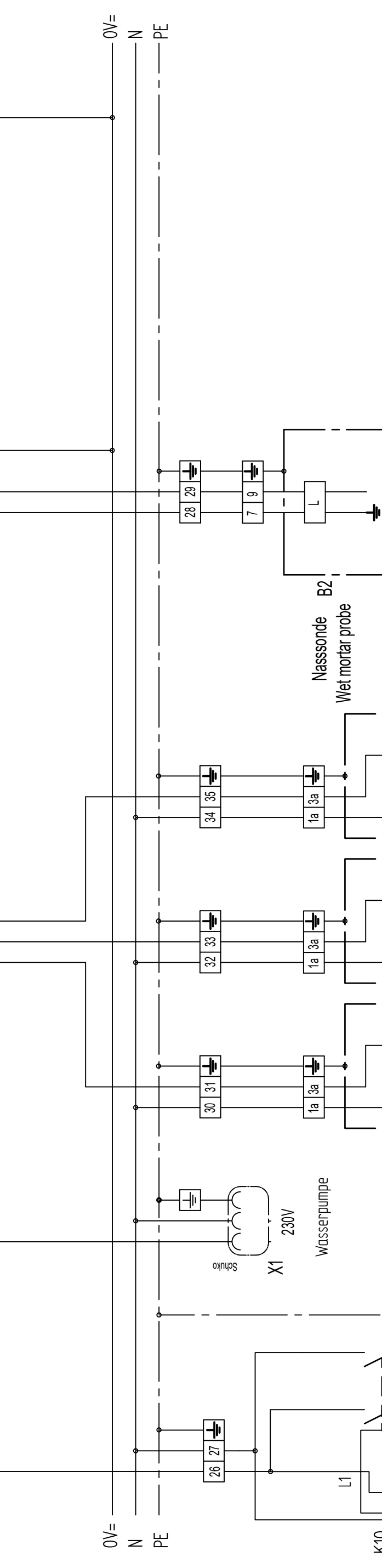
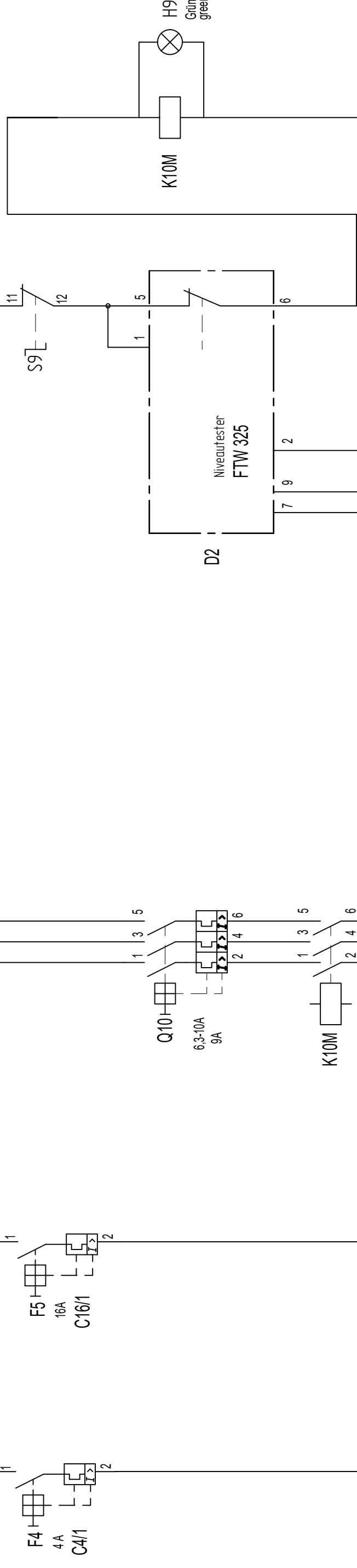
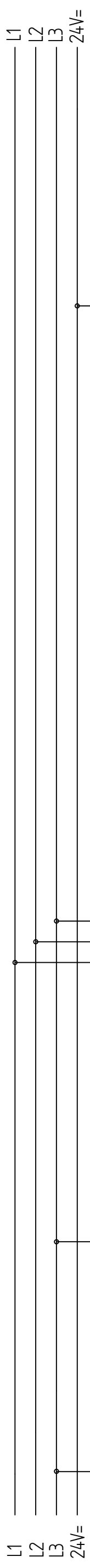

Tag	Name
30.11.2017	G.F.
Gez.	
Gepr.	
Norm.	
Rev. A	
Rev. B	
Rev. C	
Rev. D	
Rev. E	

	UELZENER MASCHINEN GmbH Stahlstrasse 26-28 65428 Rüsselsheim
ESTROMAT E426-5 FU-Version	Artikel Nr. 426.46.001.5 Art der Änderung

C-1801-24FU	
CAD Zeichnungen	Seit E426/Elektroschaltplane C-1801-24-FU/ff
Urspr.	
Ers. fuer:	
Ers. durch:	
Massstab	1 : X

Tolerierung nach DIN ISO 8015
 Allgem. Toleranzen für Schweiß- und Biegekonstruktionen: DIN 8570 T1B / T3F
 Allgem. Toleranzen für Maßtolerierung, Form und Lage : DIN ISO 2768-m

Das Urheberrecht an dieser Zeichnung verbleibt bei uns.
 Diese Zeichnung darf weder kopiert noch Dritten zugänglich gemacht oder anderweitig missbräuchlich benutzt werden.

UELZENER

MASCHINEN GmbH

Das UELZENER Maschinen-Programm The UELZENER Machine Programme

für den Hochbau

- Verputzmaschinen mit Mischer
- Mischpumpen für Fertigmörtel
- Mörtelpumpen
- Estrich -Misch- und -Förderanlagen
- Fließestrichpumpen
- Betonförderer
- Förderanlagen für Fertigmörtel
- Schaumzementmaschinen

für den Bergbau

- Hinterfüll-Mischpumpen
- Schaummörtel-Mischpumpen
- Schneckenpumpen für Bergbaumörtel
- Durchlaufmischer für Bergbaumörtel
- Mischanlagen für Verfüllmörtel
- Rohrschneckenförderer

für den Tunnel-und Tiefbau

- Anker-Verpreßpumpen
- Injektions- und Verfüllanlagen
- Tübbing-Hinterfüll-Anlagen
- Pneumatische Betonförderer
- Betonnaßspritzmaschinen

für den Feuerfestbereich

- Mischpumpen für Tundish-Spritzmassen
- Misch- und Förderanlagen für Vibrationsmassen
- Kolbenpumpen für Feuerfestmassen
- Durchlaufmischer für Feuerfestmassen
- Trockengutmischer für Feuerfestmassen

für Industrie, Umwelt und Entsorgung

- Dickstoff-Pumpen
- Vermörtelungsanlagen für Abfallstoffe
- Kalkmilch-Mischanlagen
- Schlamm-Kalk-Behandlungsanlagen
- Mörtel-Beschichtungsanlagen
- Mehrkomponenten-Misch-und-Förderanlagen

for Building Construction

- Plaster- and rendering machines with mixer
- Mixing pumps for ready-mixed mortars
- Mortar pumps
- Mixing and conveying systems for floor screed
- Self-levelling screed pumps
- Concrete conveyors
- Conveying systems for pre-mixed dry materials
- Foam cement machines

for Mining

- Back-filling mixing pumps
- Foam-cement mixing pumps
- Worm-type pumps for mining mortar
- Continuous mixers for mining mortar
- Mixing units for filling mortar
- Pipe-type worm conveyors for mining mortar

for Tunnelling and Civil Engineering

- Anchor filling pumps
- Injection and filling units
- Concrete tiles - back-filling units
- Pneumatic concrete conveyors
- Wet shotcrete machines

for Refractories

- Mixing pumps for tundish spraying masses
- Mixing and conveying systems for vibration materials
- Piston pumps for refractories
- Continuous mixers for refractories
- Dry material mixers for refractories

for Industry, Environment and Waste Disposal

- Pumps for thick matter
- Mortar systems for waste disposal
- Lime slurry mixing systems
- Sludge-lime processing units
- Mortar coating units
- Mixing and conveying units for multiple components



UELZENER MASCHINEN GmbH

Stahlstrasse 26 - 28
D-65428 Rüsselsheim
Germany

Tel. +49-(0)6142 177 68 0
Fax +49-(0)6142 177 68 50

e-mail: contact@uelzener-ums.de
Internet: www.uelzener-ums.de